



UNIVERSITY OF CAMBRIDGE INTERNATIONAL EXAMINATIONS
International General Certificate of Secondary Education

CANDIDATE NAME

CENTRE NUMBER

--	--	--	--	--

CANDIDATE NUMBER

--	--	--	--

* 3 1 7 2 8 9 5 5 1 0 *

COMBINED SCIENCE

0653/02

Paper 2 (Core)

October/November 2008

1 hour 15 minutes

Candidates answer on the Question Paper.

No Additional Materials are required.

READ THESE INSTRUCTIONS FIRST

Write your Centre number, candidate number and name on all the work you hand in.

Write in dark blue or black pen.

You may use a soft pencil for any diagrams, graphs, tables or rough working.

Do not use staples, paper clips, highlighters, glue or correction fluid.

DO NOT WRITE IN ANY BARCODES.

Answer **all** questions.

A copy of the Periodic Table is printed on page 20.

At the end of the examination, fasten all your work securely together.

The number of marks is given in brackets [] at the end of each question or part question.

For Examiner's Use	
1	
2	
3	
4	
5	
6	
7	
8	
9	
10	
Total	

This document consists of **18** printed pages and **2** blank pages.



1 Fig. 1.1 shows a food web.

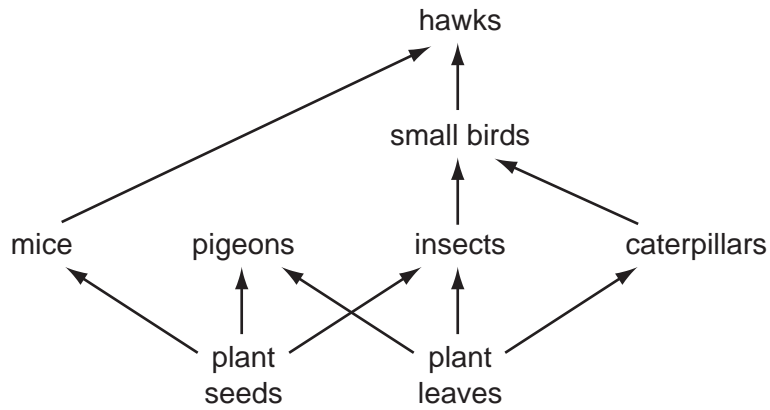

Fig. 1.1

(a) (i) State what the arrows in Fig. 1.1 represent.

..... [1]

(ii) State the numbers of different producers and consumers named in this food web.

producers

consumers [1]

(iii) No decomposers are shown in the food web.

Which organisms in the web provide food for decomposers?

..... [1]

(b) The plant seeds that a mouse eats are digested in its alimentary canal.

(i) Explain what digestion is, and why digestion is necessary.

.....
.....
..... [2]

(ii) State **two** ways by which food is digested in the alimentary canal.

1
2 [2]

(c) When an insect respire, it releases carbon dioxide into the air.

Describe how this carbon dioxide could become part of a glucose molecule in a plant leaf.

.....
.....
..... [2]

2 (a) An inflatable ball is floating on the sea without moving.

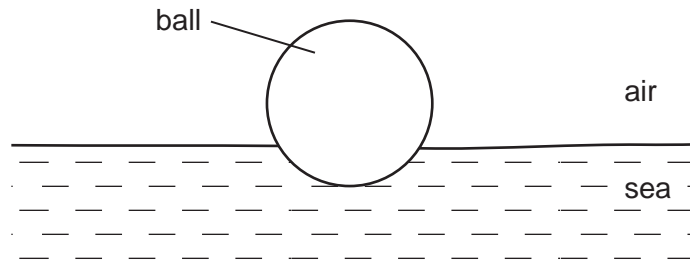

Fig. 2.1

(i) On Fig. 2.1 draw arrows to represent the two forces acting. Label each force with its name. [2]

(ii) Are these two forces balanced or unbalanced?

Explain your answer.

.....
..... [1]

(b) Three waves reach a nearby beach in ten seconds.

State the frequency of the waves.

..... Hz [1]

(c) The power of the waves can be used as a renewable source of energy.

(i) Suggest how the motion of the waves could be converted into electrical energy.

.....
.....
..... [2]

(ii) Suggest **one** other renewable source for generating electricity.

..... [1]

- (d) People on the beach are exposed to many forms of electromagnetic radiation.

Which type of electromagnetic radiation causes the skin to tan?

..... [1]

- (e) Someone has left a glass bottle on the beach. The curved glass acts like a lens focussing the sun's rays.

Complete the light rays on Fig. 2.2 to show what happens to rays of light after they have passed through a convex lens.

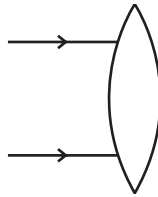

Fig. 2.2

[2]

- 3 (a) Fig. 3.1 shows two cars **A** and **B**.

Car **A** produces exhaust gases which appear black. The exhaust gases from car **B** cannot be seen. Both cars have engines which use diesel (gas oil) which is a hydrocarbon fuel.

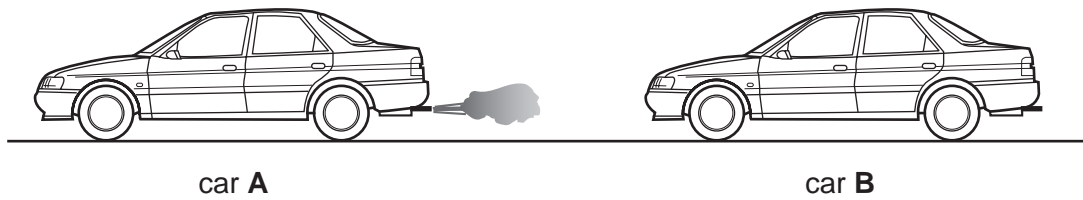

Fig. 3.1

- (i) Name the raw material from which hydrocarbon fuels like diesel are obtained.

..... [1]

- (ii) Gasoline (petrol) is another liquid hydrocarbon fuel used in cars. Gasoline and diesel are obtained by the process of fractional distillation.

State **one** difference between the properties of diesel and of gasoline which allows them to be separated by fractional distillation.

.....
..... [1]

- (iii) Name **two** compounds which are produced when hydrocarbons undergo complete combustion.

1

2 [2]

- (iv) Describe briefly how exhaust gases are thought to be contributing to climate changes.

.....
.....
..... [2]

- (b) The energy needed to move cars is provided by the combustion of the fuel. Air is supplied to the engine for this combustion to occur.

Fig. 3.2 shows a bar chart of the main gases in a sample of dry air.

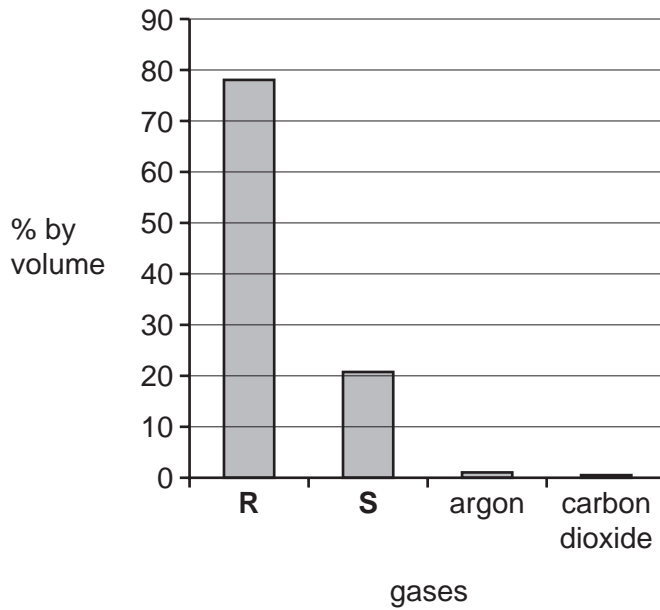

Fig. 3.2

- (i) Name gases **R** and **S** in Fig. 3.2.

gas **R**

gas **S** [2]

- (ii) Air contains small amounts of the gases argon and carbon monoxide. The amount of argon is typically much greater than that of the toxic gas carbon monoxide.

Explain why the argon in air is not harmful to humans.

.....

.....

..... [2]

4 A girl is competing in a 100 m race.

(a) (i) The girl completes the race in 14.4 seconds.

Calculate her average speed.

State the formula that you use and show your working.

formula

working

..... m/s [2]

(ii) During the first three seconds of the race the girl runs with constant acceleration from a speed of 0 m/s to a speed of 5 m/s.

Calculate her acceleration.

State the formula that you use and show your working.

formula

working

..... m/s² [2]

(b) The girl then competes in the high jump.

Just before she reaches the bar she begins to move upwards.

Describe the energy changes that take place between the girl taking off and landing after the jump.

.....
.....
..... [3]

5 This article appeared in a newspaper in Pakistan in 2006.

Many more people in Pakistan and India are developing diabetes. This is an illness where the regulation of blood glucose does not work properly.

Doctors think that the increase in diabetes is happening because people are eating more fast food. Where they used to eat a lot of rice and lentils, they are now eating more fried foods and greasy take-aways.

As well as increasing the risk of diabetes, this diet is causing an increase in obesity. This also increases the risk of heart disease.

(a) (i) Name the hormone that is produced when the blood glucose level rises, and which helps to bring it back down to normal.

..... [1]

(ii) Name the gland that secretes this hormone.

..... [1]

(iii) Describe how the hormone reduces the amount of glucose in the blood.

.....
.....
..... [2]

(b) (i) Suggest why eating foods containing a lot of fat, rather than eating lentils and rice, can lead to a person becoming overweight.

.....
.....
..... [2]

(ii) An overweight person has an increased risk that a blockage will occur in a coronary artery.

Explain how a blockage in a coronary artery could cause a heart attack.

.....
.....
..... [2]

6 The chemical symbols for two elements are shown below.



These symbols represent one atom of each element.

(a) (i) Name the **three** smaller particles which make up these atoms.

..... [1]

(ii) What do the numbers 12 and 24 indicate about the structure of one atom of magnesium?

.....
..... [2]

(b) A student used the apparatus in Fig. 6.1 to burn magnesium in air.

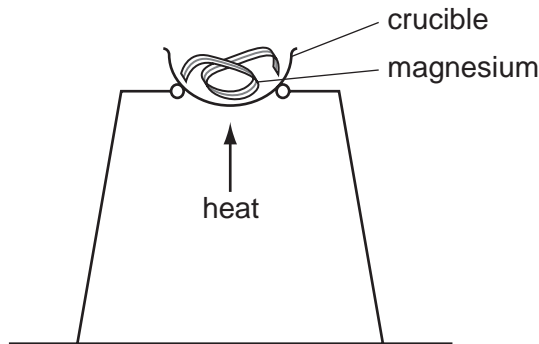
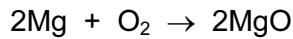

Fig. 6.1

As a result of the reaction, the piece of magnesium changed into a white solid.

The balanced equation for the reaction is shown below.



(i) Write the **word** equation for this reaction.

..... [1]

(ii) Write the name or formula of the substance shown above in the equation which contains ionic bonds.

Explain your answer briefly.

substance

explanation

..... [2]

(c) The student then added some magnesium to some dilute sulphuric acid contained in test-tube **A**. He also added some of the white solid produced by the reaction in (b) to some dilute sulphuric acid in test-tube **B** as shown in Fig. 6.2.

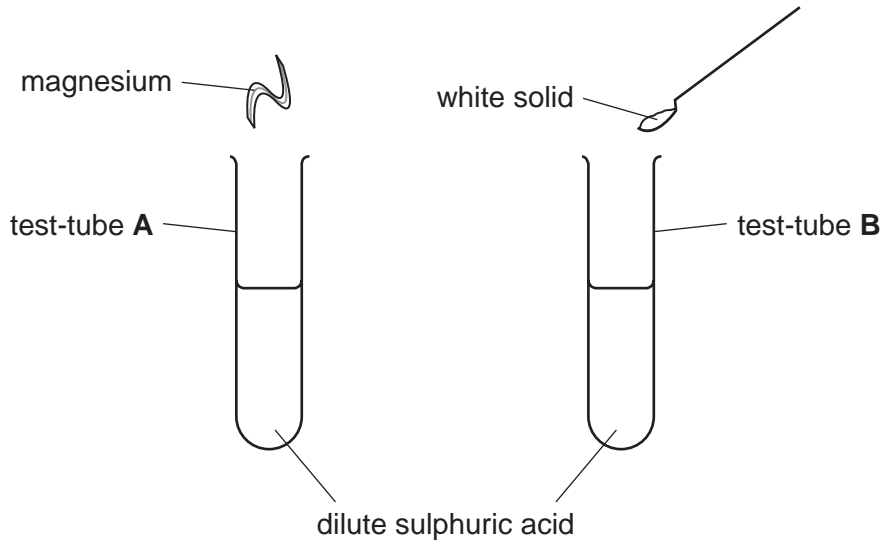

Fig. 6.2

At the end of the reactions a colourless solution remained in both test tubes.

(i) One of the reactions in Fig. 6.2 produced a gas.

In which test-tube, **A** or **B**, were gas bubbles observed?

Explain your answer.

test-tube

explanation

..... [2]

(ii) The formula of the gas produced in (i) is H_2 .

State and explain whether this gas is an element or a compound.

.....

..... [1]

(iii) After the reactions had finished, both test-tubes contained the same compounds. One of these was water.

Name the other compound present in both tubes.

..... [1]

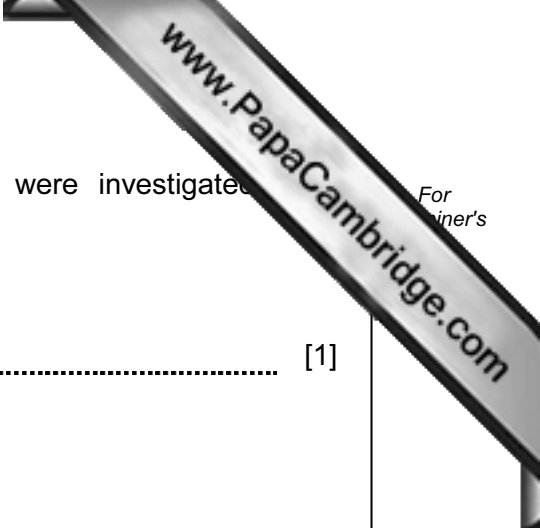

- 7 (a) The radioactive emissions from a sample of radon-220 were investigated. The radiation emitted was measured every hour for 10 hours.

State the apparatus needed for this.

..... [1]

- (b) Radon is a gas that emits alpha radiation.

Explain why alpha radiation is dangerous to human beings.

.....
.....
..... [2]

- (c) Radioactivity can be useful to humans. Apart from the generation of electricity, describe **one** use of radioactivity.

.....
.....
..... [2]



Please turn over for Question 8

8 Fig. 8.1 shows part of the male reproductive system.

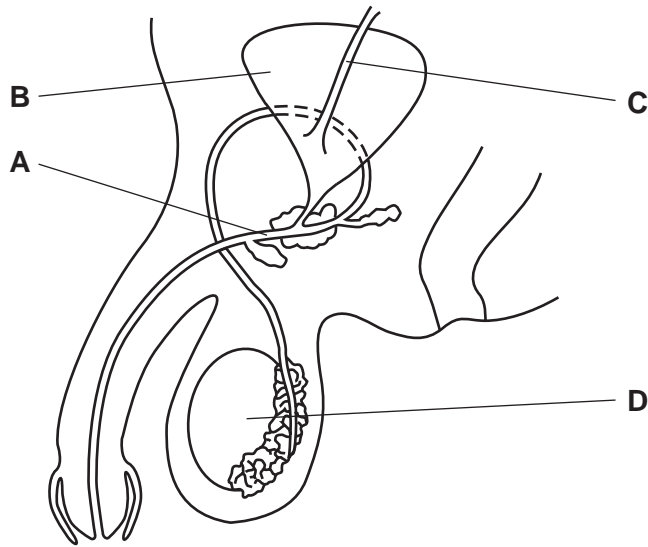

Fig. 8.1

(a) Give the letter of each of these parts.

(i) where sperm are made

(ii) where urine is stored

(iii) the ureter

(iv) the urethra

[4]

(b) On Fig. 8.1, write the letter **X** to show the part of the reproductive system which is cut or tied when a man has a sterilisation operation. [1]

(c) Fig. 8.2 shows a sperm.



Fig. 8.2

(i) On Fig. 8.2, name and label **two** structures that are found in all animal cells. [2]

(ii) Describe **two** ways in which a sperm is adapted for its function.

1

.....

2

..... [2]

- 9 (a) Fig. 9.1 shows part of the Periodic Table. The letters are not the chemical symbols of elements.

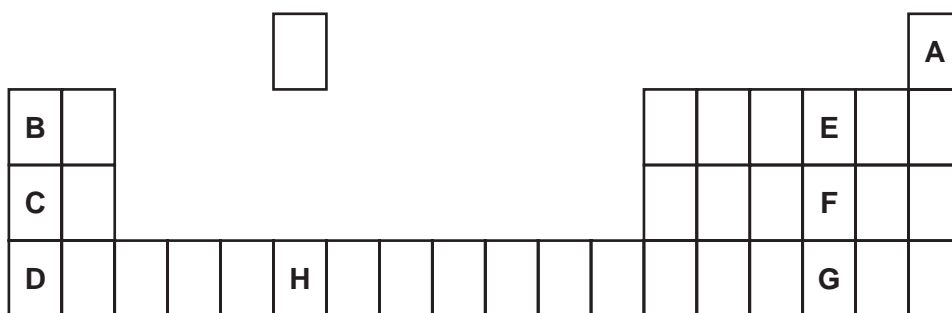

Fig. 9.1

Choose **one** of the letters from **A** to **H**, which shows an element whose atoms have only one electron shell,

..... [1]

an element in the same period as element **D**.

..... [1]

- (b) Calcium carbonate, CaCO_3 , is an important compound used in many industries.

A student used the apparatus in Fig. 9.2 to investigate what happens when calcium carbonate is heated strongly.

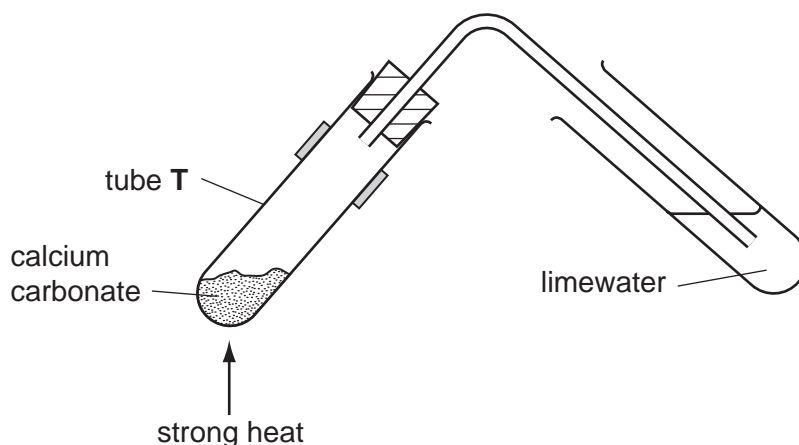
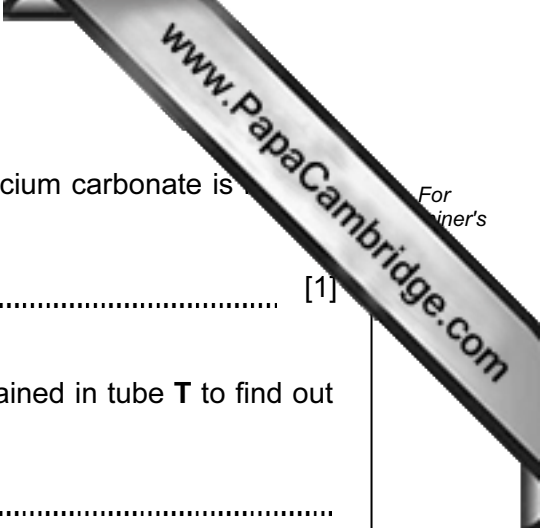

Fig. 9.2

During the experiment many gas bubbles passed through the limewater, which turned cloudy. A white solid remained in tube T after the student stopped heating.

- (i) Complete the word equation for the reaction.

calcium carbonate \rightarrow calcium oxide + [1]



(ii) State the type of chemical reaction that occurs when calcium carbonate is heated strongly.

..... [1]

(iii) Describe how the student could test the solid which remained in tube T to find out if all the calcium carbonate had reacted.

.....
.....
.....
..... [3]

10 (a) (i) The diagram in Fig. 10.1 shows a circuit with a two-way switch, **S**.

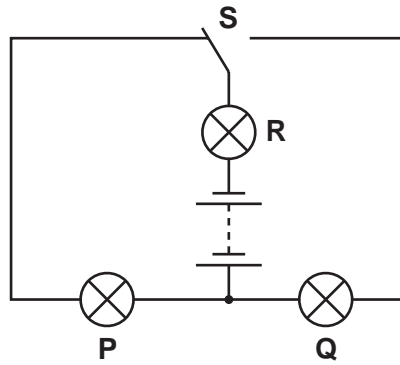

Fig. 10.1

Complete the table below to show if each lamp is on or off when switch **S** is in the position shown.

Write 'on' or 'off' for each lamp.

lamp	on or off
P	
Q	
R	

[2]

(ii) Name the component in the circuit which provides the energy for the circuit.

..... [1]

(b) A student has three resistors as shown in Fig. 10.2.

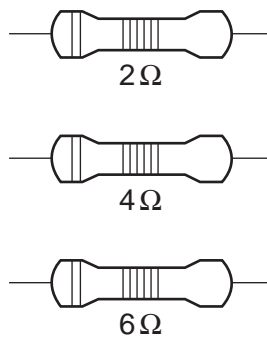

Fig. 10.2

Explain how he can combine **two** of these resistors to get a total resistance of 10 ohms.

.....
..... [2]

